

ROOF TOP PV MOUNTING SYSTEM

THIS PRODUCT HAS BEEN DESIGNED AND TESTED TO COMPLY WITH THE REQUIREMENTS OF THE 2023 (8TH EDITION) FLORIDA BUILDING CODE FOR NON HIGH VELOCITY HURRICANE ZONE.

THIS PRODUCT APPROVAL IS FOR THE ROOF TOP PV MOUNTING SYSTEM AS SHOWN ON THESE DRAWINGS. ROOF DETAILS, UPLIFT, SLOPE, ROOF TRUSSES AND OTHER ELEMENTS SHALL BE DESIGNED BY A FLORIDA REGISTERED ENGINEER AND REVIEWED BY THE STRUCTURAL PLANS EXAMINER OF THE CORRESPONDING BUILDING DEPARTMENT. ENGINEER OF RECORD TO VERIFY THAT ROOF MEMBERS CAN SUPPORT THE PV MODULE ARRAY UNDER ALL CODE LEVEL LOADING CONDITIONS. INSTALLER TO MAINTAIN THE WATERPROOF INTEGRITY OF THE ROOF.

INSTALLATION OF PV PANEL ACCESSORIES SHALL BE DONE IN ACCORDANCE WITH THE CURRENT EDITION OF FLORIDA BUILDING CODE AND THE MANUFACTURER'S INSTALLATION INSTRUCTIONS.

ANCHORS SHALL BE CORROSION RESISTANT, SPACED AS SHOWN ON DETAILS AND INSTALLED PER MANUF'S INSTRUCTIONS. SPECIFIED EMBEDMENT TO BASE MATERIAL SHALL BE BEYOND ROOF COVERING.

DESIGN LOADS SHOWN ARE BASED ON 'ALLOWABLE STRESS DESIGN (ASD)'. SOLAR PANELS TO BE INSTALLED PARALLEL TO THE ROOF SURFACE WITH A TOLERANCE OF LESS THAN 2 DEGREES.

CONDITIONS NOT SHOWN IN THIS DRAWING ARE TO BE ANALYZED SEPARATELY, AND TO BE REVIEWED BY BUILDING OFFICIAL.

INSTRUCTIONS:

USE CHARTS AS FOLLOWS.

- STEP 1** DETERMINE DESIGN WIND LOAD REQUIREMENT BASED ON WIND VELOCITY, BLDG. HEIGHT, WIND ZONE USING APPLICABLE ASCE 7 STANDARD.
- STEP 2** SELECT LIGHT RAIL OR MAX. RAIL FOR REQUIRED LOADS FROM LANDSCAPE OR PORTRAIT RAIL CAPACITY CHARTS SHOWN ON SHEET 4.
- STEP 3** VERIFY HIDDEN & MULTI-CLAMP CAPACITY USING CHART ON SHEET 4.
- STEP 4** SELECT ROOF MOUNT CAPACITY FOR LANDSCAPE OR PORTRAIT INSTALLATIONS USING CHARTS ON SHEET 5, WITH RATING MORE THAN DESIGN LOAD SPECIFIED IN STEP 1 ABOVE.
- STEP 5** THE LOWEST VALUE RESULTING FROM STEPS 2, 3 AND 4 SHALL APPLY TO ENTIRE SYSTEM.

PV PANELS NOT PART OF THIS APPROVAL. FOR PANEL DETAILS, GENERAL NOTES, COMPONENT SIZES, FIRE AND ELECTRICAL SAFETY STANDARDS, PANEL CONNECTION TO MOUNTS AND INSTALLATION REQUIREMENTS/LIMITATIONS SEE CORRESPONDING FLA. APPROVAL DWGS.

Sealed: 8/11/2023

FL #41396

- A- CONTRACTOR TO BE RESPONSIBLE FOR THE SELECTION, PURCHASE AND INSTALLATION OF THIS PRODUCT BASED ON THIS PRODUCT EVALUATION PROVIDED HE/SHE DOES NOT DEVIATE FROM THE CONDITIONS DETAILED ON THIS DOCUMENT.
- B- THIS PRODUCT EVALUATION DOCUMENT WILL BE CONSIDERED INVALID IF ALTERED BY ANY MEANS.
- C- SITE SPECIFIC PROJECTS SHALL BE PREPARED BY A FLORIDA REGISTERED ENGINEER OR ARCHITECT WHICH WILL BECOME THE ENGINEER OF RECORD (E.O.R.) FOR THE PROJECT AND WHO WILL BE RESPONSIBLE FOR THE PROPER USE OF THE P.E.D. ENGINEER OF RECORD, ACTING AS A DELEGATED ENGINEER TO THE P.E.D. ENGINEER SHALL SUBMIT TO THIS LATTER THE SITE SPECIFIC DRAWINGS FOR REVIEW.
- D- THIS P.E.D. SHALL BEAR THE DATE AND ORIGINAL SEAL AND SIGNATURE OF THE PROFESSIONAL ENGINEER OF RECORD THAT PREPARED IT.

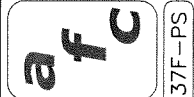
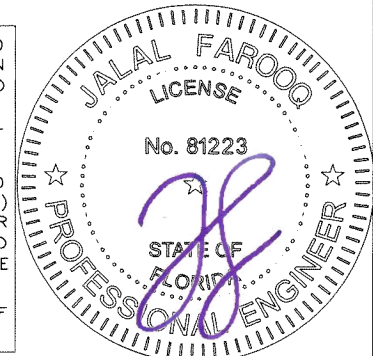

AL-FAROOQ CORPORATION
ENGINEERS & PRODUCT DEVELOPMENT
9360 SUNSET DRIVE, SUITE 220
MIAMI, FLORIDA 33173
TEL. (305) 264-8100
WWW.AFCENG.COM
FBPE #3538
SOLAR-RACK\23-37F-PS

ROOF TOP PV MOUNTING SYSTEM

Pegasus Solar Inc.
506 West Ohio Avenue
Richmond CA. 94804
Phone: (510) 210-3797
www.pegasussolar.com

no	date	description

date: 08-08-23
scale: 1/2"=1'-0"
dr. by: TARIQ
chk. by:

drawing no.

23-37F

sheet 1 of 6

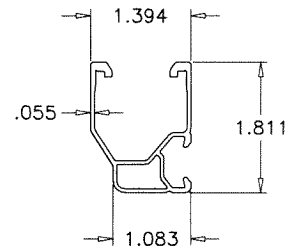

LIGHT RAIL

6000 SERIES ALUMINUM
 (Fy MIN. = 35.0 KSI)
 (Fu MIN. = 38.0 KSI)
 (Kt = 1.0)

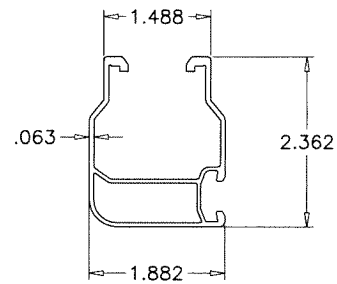

MAX. RAIL

6000 SERIES ALUMINUM
 (Fy MIN. = 35.0 KSI)
 (Fu MIN. = 38.0 KSI)
 (Kt = 1.0)

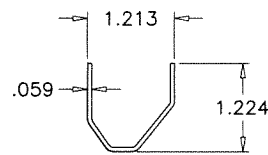

LIGHT RAIL SPLICE

300 SERIES ST. STEEL OR EQUIVALENT
 (Fy MIN. = 110.0 KSI)
 (Fu MIN. = 150.0 KSI)

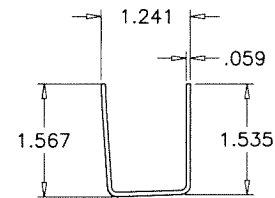

MAX. RAIL SPLICE

300 SERIES ST. STEEL OR EQUIVALENT
 (Fy MIN. = 110.0 KSI)
 (Fu MIN. = 150.0 KSI)

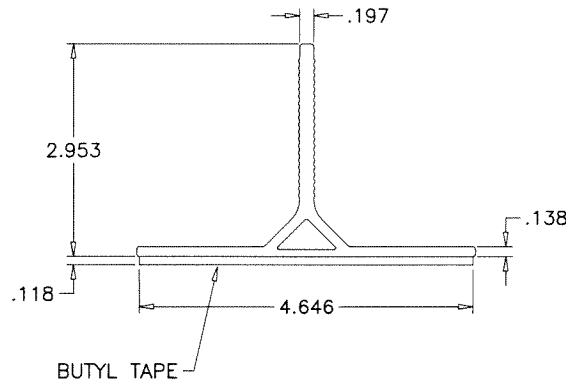
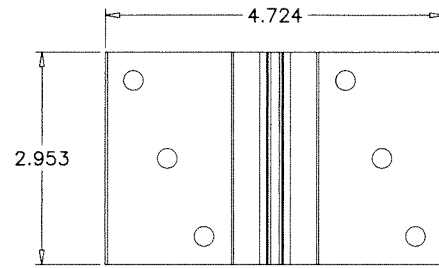

Butyl-Foot MOUNT

6000 SERIES ALUMINUM
 (Fy MIN. = 35.0 KSI)
 (Fu MIN. = 38.0 KSI)

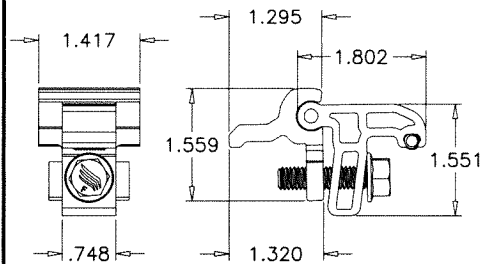

HIDDEN END CLAMP

6000 SERIES ALUMINUM
 (Fy MIN. = 35.0 KSI)
 (Fu MIN. = 38.0 KSI)

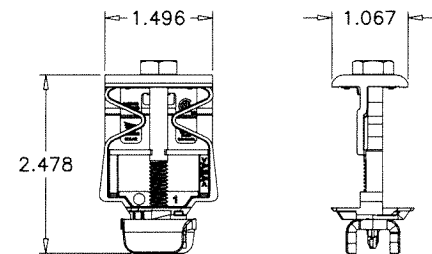

MULTI-CLAMP

6000 SERIES ALUMINUM
 (Fy MIN. = 35.0 KSI)
 (Fu MIN. = 38.0 KSI)

Sealed: 8/11/2023

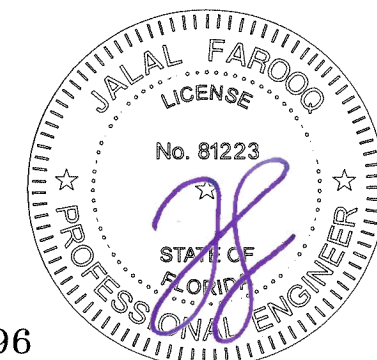

FL #41396

afC
AL-FAROOQ CORPORATION
 ENGINEERS & PRODUCT DEVELOPMENT
 9360 SUNSET DRIVE, SUITE 220
 MIAMI, FLORIDA 33173
 TEL. (305) 264-8100
 WWW.AFCENG.COM
 FBPE #3538
 SOLAR-RACK\23-37F-PS

ROOF TOP PV MOUNTING SYSTEM
Pegasus Solar Inc.
 506 West Ohio Avenue
 Richmond CA. 94804
 Phone: (510) 210-3797
 www.pegassussolar.com

revisions:	no	date	by	description

date: 08-08-23
 scale: 3/8" = 1"
 dr. by: TARIQ
 chk. by:

drawing no.
23-37F
 sheet 2 of 6

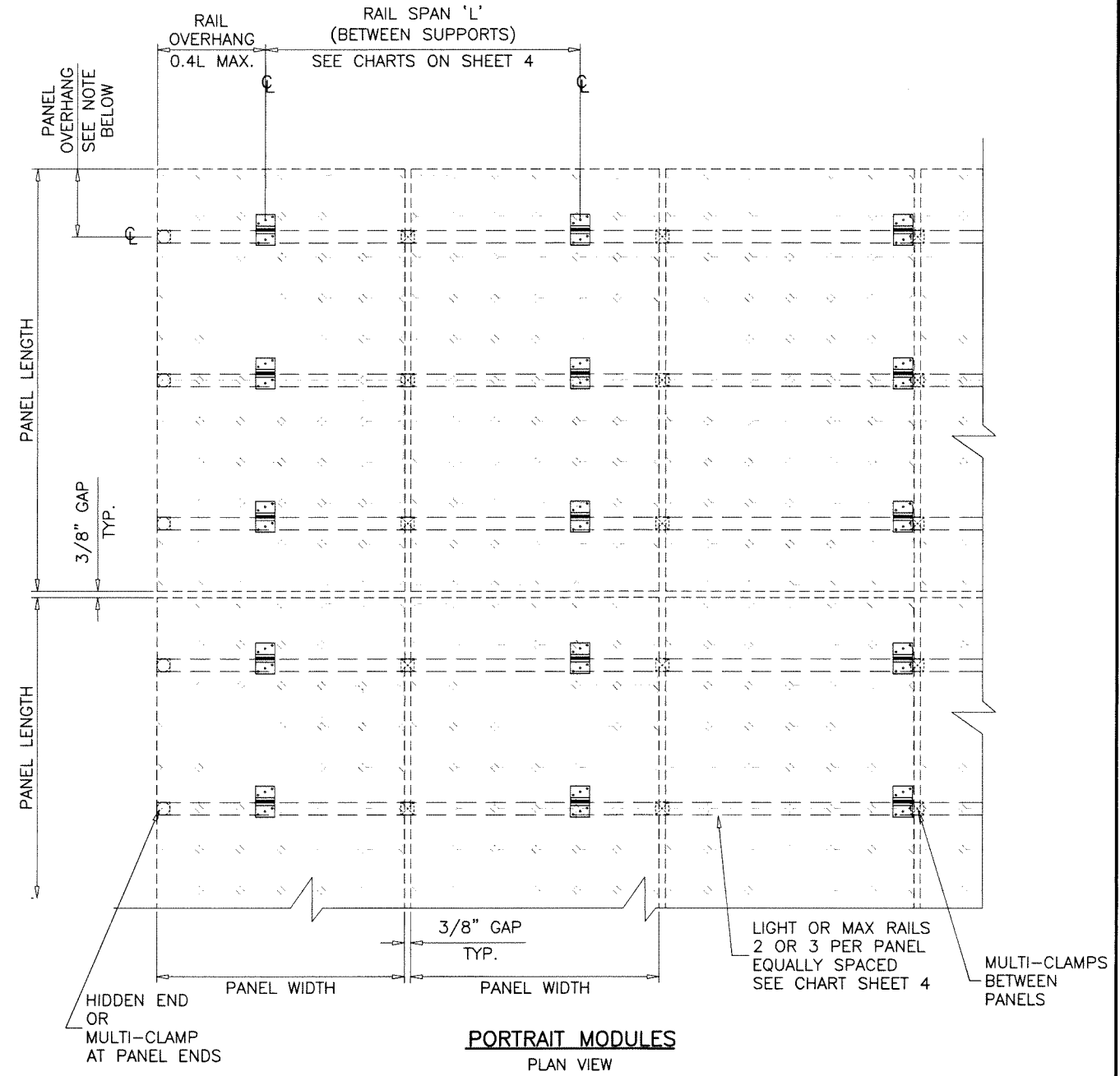
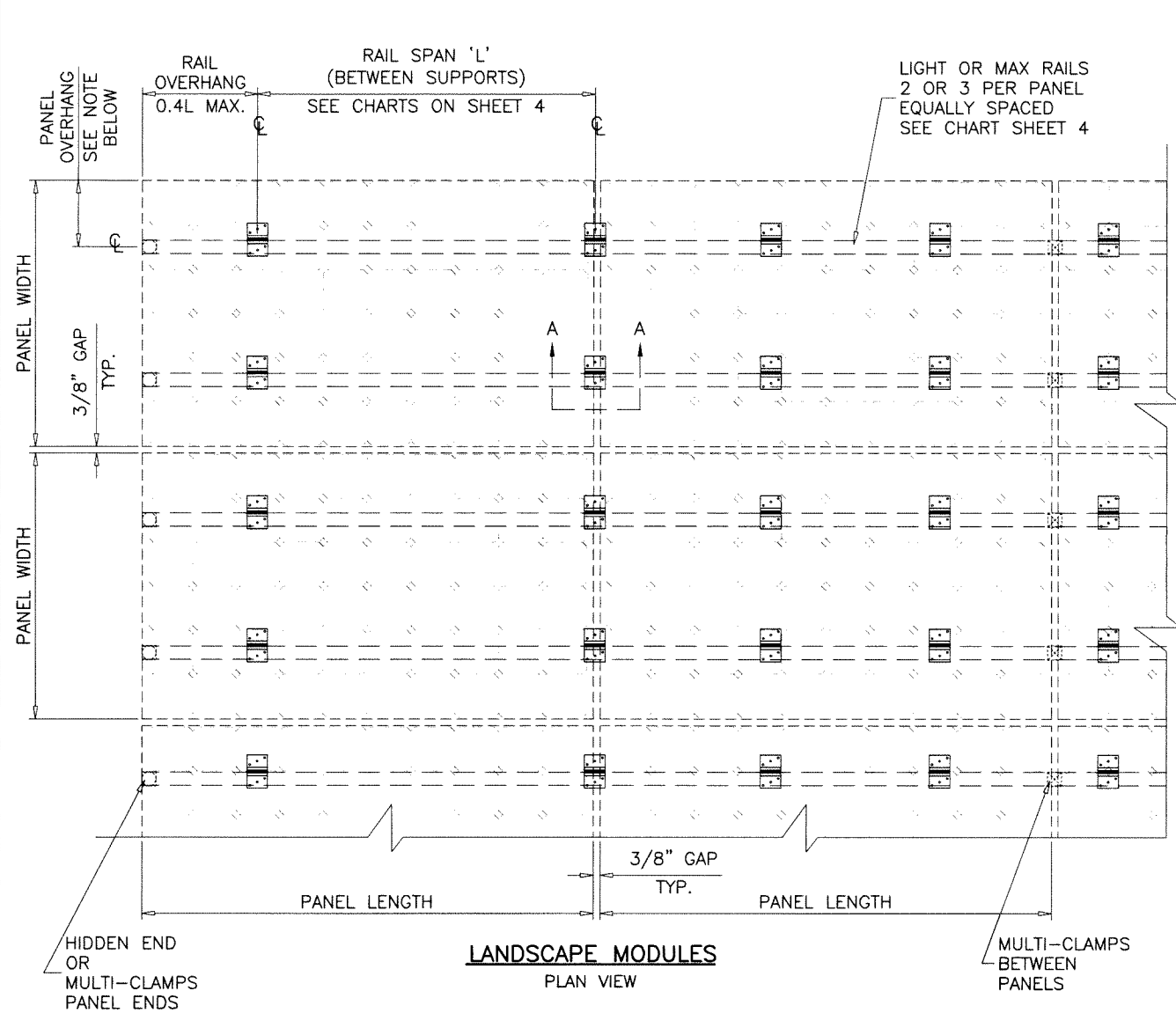

NOTES:
 PANEL OVERHANG AS PER PANEL MANUFACTURER'S INSTRUCTIONS.
 SHOULD BE EQUAL ON BOTH SIDES OF PANELS
 FOR 3 RAILS SUPPORTED PANELS, OVERHANGS TO BE
 BETWEEN 12-20% OF PANEL LENGTH OR WIDTH.

RAILS CAN BE JOINED WITH 6.9" LONG SPLICE TO ACHIEVE REQUIRED LENGTHS.
 SPLICE JOINTS TO BE ANYWHERE ALONG THE RAIL EXCEPT NO PART OF THE
 SPLICE SHOULD BE WITHIN THE RAIL CANTILEVER.

Sealed: 8/11/2023

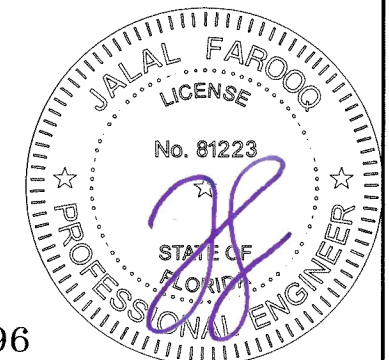

FL #41396

af c
AL-FAROOQ CORPORATION
 ENGINEERS & PRODUCT DEVELOPMENT
 9360 SUNSET DRIVE, SUITE 220
 MIAMI, FLORIDA 33173
 TEL. (305) 264-8100
 FBPE #3538
 WWW.AFCENG.COM
 SOLAR-RACK\23-37F-PS

ROOF TOP PV MOUNTING SYSTEM
Pegasus Solar Inc.
 506 West Ohio Avenue
 Richmond CA. 94804
 Phone: (510) 210-3797
 www.pegassussolar.com

revisions:	no	date	by	description

date: 08-08-23
 scale: 1/2"=1'-0"
 dr. by: TARIQ
 chk. by:

drawing no.
23-37F
 sheet 3 of 6

LIGHT RAIL & MAX. RAIL

RAILS DESIGN LOAD CAPACITY - PSF (LANDSCAPE MODULES)												
PANEL LENGTH	NUMBER OF RAILS	SPAN 'L'	FLAT ROOFS		ROOF SLOPES UP TO 7°		ROOF SLOPES 8° TO 20°		ROOF SLOPES 21° TO 27°		ROOF SLOPES 28° TO 45°	
			LIGHT RAIL	MAX. RAIL	LIGHT RAIL	MAX. RAIL	LIGHT RAIL	MAX. RAIL	LIGHT RAIL	MAX. RAIL	MAX. RAIL	LIGHT RAIL
69-1/2"	2	16"	115.0	115.0	115.0	115.0	115.0	115.0	115.0	115.0	115.0	115.0
		24"	115.0	115.0	115.0	115.0	115.0	115.0	115.0	115.0	115.0	115.0
		32"	115.0	115.0	115.0	115.0	115.0	115.0	115.0	115.0	115.0	115.0
		48"	64.0	112.0	63.5	111.5	62.4	110.6	61.7	110.0	59.9	108.4
		64"	37.7	64.7	37.2	64.3	36.1	63.3	35.5	62.7	33.7	61.1
	72"	30.7	52.0	30.1	51.5	29.0	50.6	28.4	50.0	26.6	48.4	
	3	16"	115.0	115.0	115.0	115.0	115.0	115.0	115.0	115.0	115.0	115.0
		24"	115.0	115.0	115.0	115.0	115.0	115.0	115.0	115.0	115.0	115.0
		32"	115.0	115.0	115.0	115.0	115.0	115.0	115.0	115.0	115.0	115.0
		48"	75.7	115.0	75.2	115.0	74.1	115.0	73.4	115.0	71.7	115.0
64"		44.4	76.6	43.8	76.2	42.7	75.2	42.1	74.6	40.3	73.0	
72"	35.9	61.4	35.4	60.9	34.2	60.0	33.6	59.4	31.8	57.8		
80"	2	16"	76.7	76.7	76.7	76.7	76.7	76.7	76.7	76.7	76.7	76.7
		24"	76.7	76.7	76.7	76.7	76.7	76.7	76.7	76.7	76.7	76.7
		32"	76.7	76.7	76.7	76.7	76.7	76.7	76.7	76.7	76.7	76.7
		48"	64.0	76.7	63.5	76.7	62.4	76.7	61.7	76.7	59.9	76.7
		64"	37.7	64.7	37.2	64.3	36.1	63.3	35.5	62.7	33.7	61.1
	72"	30.7	52.0	30.1	51.5	29.0	50.6	28.4	50.0	26.6	48.4	
	3	16"	115.0	115.0	115.0	115.0	115.0	115.0	115.0	115.0	115.0	115.0
		24"	115.0	115.0	115.0	115.0	115.0	115.0	115.0	115.0	115.0	115.0
		32"	115.0	115.0	115.0	115.0	115.0	115.0	115.0	115.0	115.0	115.0
		48"	75.7	115.0	75.2	115.0	74.1	115.0	73.4	115.0	71.7	115.0
64"		44.4	76.6	43.8	76.2	42.7	75.2	42.1	74.6	40.3	73.0	
72"	35.9	61.4	35.4	60.9	34.2	60.0	33.6	59.4	31.8	57.8		

LIMIT MAXIMUM POSITIVE(+) LOADS TO 75.0 PSF

LIGHT RAIL & MAX. RAIL

RAILS DESIGN LOAD CAPACITY - PSF (PORTRAIT MODULES)												
PANEL LENGTH	NUMBER OF RAILS	SPAN 'L'	FLAT ROOFS		ROOF SLOPES UP TO 7°		ROOF SLOPES 8° TO 20°		ROOF SLOPES 21° TO 27°		ROOF SLOPES 28° TO 45°	
			LIGHT RAIL	MAX. RAIL	LIGHT RAIL	MAX. RAIL	LIGHT RAIL	MAX. RAIL	LIGHT RAIL	MAX. RAIL	LIGHT RAIL	MAX. RAIL
69-1/2"	2	16"	115.0	115.0	115.0	115.0	115.0	115.0	115.0	115.0	115.0	115.0
		24"	115.0	115.0	115.0	115.0	115.0	115.0	115.0	115.0	115.0	115.0
		32"	83.8	115.0	83.3	115.0	82.2	115.0	81.5	115.0	79.8	115.0
		48"	39.5	67.9	38.9	67.4	37.8	66.4	37.2	65.8	35.4	64.2
		64"	24.0	39.9	23.4	39.5	22.3	38.5	21.7	37.9	19.9	36.3
	72"	19.8	32.4	19.2	31.9	18.1	31.0	17.5	30.4	15.7	28.8	
	3	16"	115.0	115.0	115.0	115.0	115.0	115.0	115.0	115.0	115.0	115.0
		24"	115.0	115.0	115.0	115.0	115.0	115.0	115.0	115.0	115.0	115.0
		32"	99.5	115.0	98.9	115.0	97.8	115.0	97.2	115.0	95.4	115.0
		48"	46.4	80.4	45.9	79.9	44.8	78.9	44.1	78.4	42.4	76.7
64"		27.9	47.0	27.3	46.5	26.2	45.5	25.6	44.9	23.8	43.3	
72"	22.9	37.9	22.3	37.5	21.2	36.5	20.6	35.9	18.8	34.3		
80"	2	16"	76.7	76.7	76.7	76.7	76.7	76.7	76.7	76.7	76.7	76.7
		24"	76.7	76.7	76.7	76.7	76.7	76.7	76.7	76.7	76.7	76.7
		32"	73.3	76.7	72.8	76.7	71.7	76.7	71.1	76.7	69.3	76.7
		48"	34.8	59.5	34.3	59.0	33.2	58.0	32.5	57.5	30.8	55.9
		64"	21.3	35.2	20.8	34.8	19.7	33.8	19.0	33.2	17.3	31.6
	72"	17.7	28.7	17.2	28.2	16.1	27.2	15.4	26.6	13.6	25.0	
	3	16"	115.0	115.0	115.0	115.0	115.0	115.0	115.0	115.0	115.0	115.0
		24"	115.0	115.0	115.0	115.0	115.0	115.0	115.0	115.0	115.0	115.0
		32"	86.9	115.0	86.4	115.0	85.3	115.0	84.6	115.0	82.9	115.0
		48"	40.9	70.3	40.3	69.9	39.2	68.9	38.6	68.3	36.8	66.7
64"		24.7	41.3	24.2	40.9	23.1	39.9	22.4	39.3	20.7	37.7	
72"	20.4	33.5	19.9	33.0	18.7	32.1	18.1	31.5	16.3	29.9		

LIMIT MAXIMUM POSITIVE(+) LOADS TO 75.0 PSF

HIDDEN CLAMP & MULTI-CLAMP

CLAMP DESIGN LOAD CAPACITY - PSF (LANDSCAPE & PORTRAIT MODULES)							
PANEL LENGTH	NUMBER OF RAILS	SPAN 'L'	FLAT ROOFS	ROOF SLOPES UP TO 7°	ROOF SLOPES 8° TO 20°	ROOF SLOPES 21° TO 27°	ROOF SLOPES 28° TO 45°
69-1/2"	2	16" TO 72"	72.2	71.2	69.4	68.3	65.7
	3	16" TO 72"	85.5	84.6	82.7	81.7	79.1
80"	2	16" TO 72"	63.2	62.3	60.4	59.4	56.8
	3	16" TO 72"	74.8	73.9	72.0	71.0	68.4

LOADS SHOWN IN CHARTS ABOVE ARE FOR 60 CELLS PANEL (41.1" X 69.5") AND 72 CELLS PANEL (41.1" X 80").

Sealed: 8/11/2023

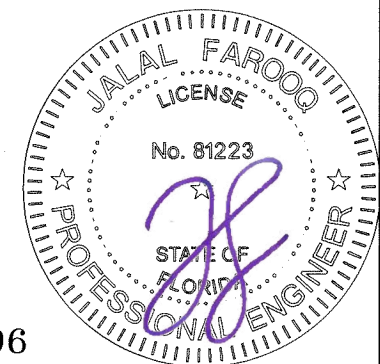

FL #41396

AL-FAROOQ CORPORATION
 ENGINEERS & PRODUCT DEVELOPMENT
 9360 SUNSET DRIVE, SUITE 220
 MIAMI, FLORIDA 33173
 TEL. (305) 264-8100
 WWW.AFCENG.COM
 FBPE #8538

ROOF TOP PV MOUNTING SYSTEM
Pegasus Solar Inc.
 506 West Ohio Avenue
 Richmond CA. 94804
 Phone: (510) 210-3797
 www.pegasussolar.com

revisions:	no.	date	by	description
date:	08-08-23	scale:	-	
dr. by:	TARIQ	chk. by:		
drawing no.	23-37F			
sheet	4 of 6			

ROOF MOUNT DESIGN LOAD CAPACITY - PSF (LANDSCAPE MODULES)							
PANEL LENGTH	NUMBER OF RAILS	SPAN 'L'	FLAT ROOFS	ROOF SLOPES UP TO 7°	ROOF SLOPES 8° TO 20°	ROOF SLOPES 21° TO 27°	ROOF SLOPES 28° TO 45°
69-1/2"	2	16"	67.9	67.7	67.1	66.7	65.5
		24"	46.6	46.4	45.8	45.4	44.2
		32"	36.0	35.7	35.1	34.7	33.5
		48"	25.3	25.1	24.5	24.1	22.9
		64"	20.0	19.7	19.1	18.7	17.5
		72"	18.2	18.0	17.4	17.0	15.8
	3	16"	80.5	80.2	79.6	79.2	78.0
		24"	55.0	54.7	54.1	53.7	52.5
		32"	42.2	42.0	41.4	41.0	39.8
		48"	29.5	29.2	28.6	28.2	27.0
		64"	23.1	22.9	22.3	21.9	20.7
		72"	21.0	20.7	20.1	19.7	18.6
80"	2	16"	67.9	67.7	67.1	66.7	65.5
		24"	46.6	46.4	45.8	45.4	44.2
		32"	36.0	35.7	35.1	34.7	33.5
		48"	25.3	25.1	24.5	24.1	22.9
		64"	20.0	19.7	19.1	18.7	17.5
		72"	18.2	18.0	17.4	17.0	15.8
	3	16"	80.5	80.2	79.6	79.2	78.0
		24"	55.0	54.7	54.1	53.7	52.5
		32"	42.2	42.0	41.4	41.0	39.8
		48"	29.5	29.2	28.6	28.2	27.0
		64"	23.1	22.9	22.3	21.9	20.7
		72"	21.0	20.7	20.1	19.7	18.6

LIMIT MAXIMUM POSITIVE(+) LOADS TO 75.0 PSF

ROOF MOUNT DESIGN LOAD CAPACITY - PSF (PORTRAIT MODULES)								
PANEL LENGTH	NUMBER OF RAILS	SPAN 'L'	FLAT ROOFS	ROOF SLOPES UP TO 7°	ROOF SLOPES 8° TO 20°	ROOF SLOPES 21° TO 27°	ROOF SLOPES 28° TO 45°	
69-1/2"	2	16"	41.8	41.6	41.0	40.6	39.4	
		24"	29.2	29.0	28.4	28.0	26.8	
		32"	22.9	22.7	22.1	21.7	20.5	
		48"	16.6	16.4	15.7	15.4	-	
	3	16"	49.2	49.0	48.4	48.0	46.8	
		24"	34.1	33.9	33.3	32.9	31.7	
		32"	26.6	26.4	25.8	25.4	24.2	
		48"	19.1	18.8	18.2	17.8	16.6	
	80"	2	16"	36.9	36.6	36.0	35.6	34.4
			24"	25.9	25.7	25.0	24.6	23.5
			32"	20.4	20.2	19.6	19.2	18.0
		3	48"	15.0	-	-	-	-
16"			43.3	43.0	42.4	42.0	40.8	
24"			30.2	29.9	29.3	28.9	27.7	
32"			23.6	23.4	22.8	22.4	21.2	
48"			17.1	16.8	16.2	15.8	-	

LIMIT MAXIMUM POSITIVE(+) LOADS TO 75.0 PSF

SEE SHEET 6 FOR Butyl-Foot MOUNT INSTALLATION

LOADS SHOWN IN CHARTS ABOVE ARE FOR 60 CELLS PANEL (41.1" X 69.5") AND 72 CELLS PANEL (41.1" X 80").

Sealed: 8/11/2023

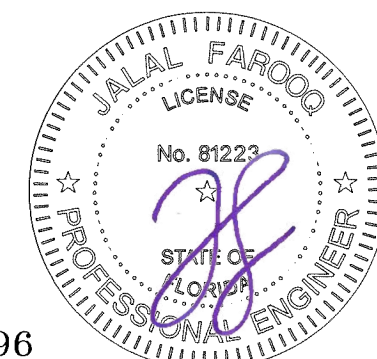

FL #41396

afc

AL-FAROOQ CORPORATION
 ENGINEERS & PRODUCT DEVELOPMENT
 9360 SUNSET DRIVE, SUITE 220
 MIAMI, FLORIDA 33173
 TEL. (305) 264-8100
 WWW.AFCENG.COM

SOLAR-RACK \ 23-37F-PS

FBPE #3538

ROOF TOP PV MOUNTING SYSTEM

Pegasus Solar Inc.
 506 West Ohio Avenue
 Richmond CA. 94804
 Phone: (510) 210-3797
 www.pegasussolar.com

revisions:
 no date by description

date: 08-08-23
 scale: -
 dr. by: TARIQ
 chk. by:

drawing no.
23-37F
 sheet 5 of 6

ButyL-Foot MOUNT

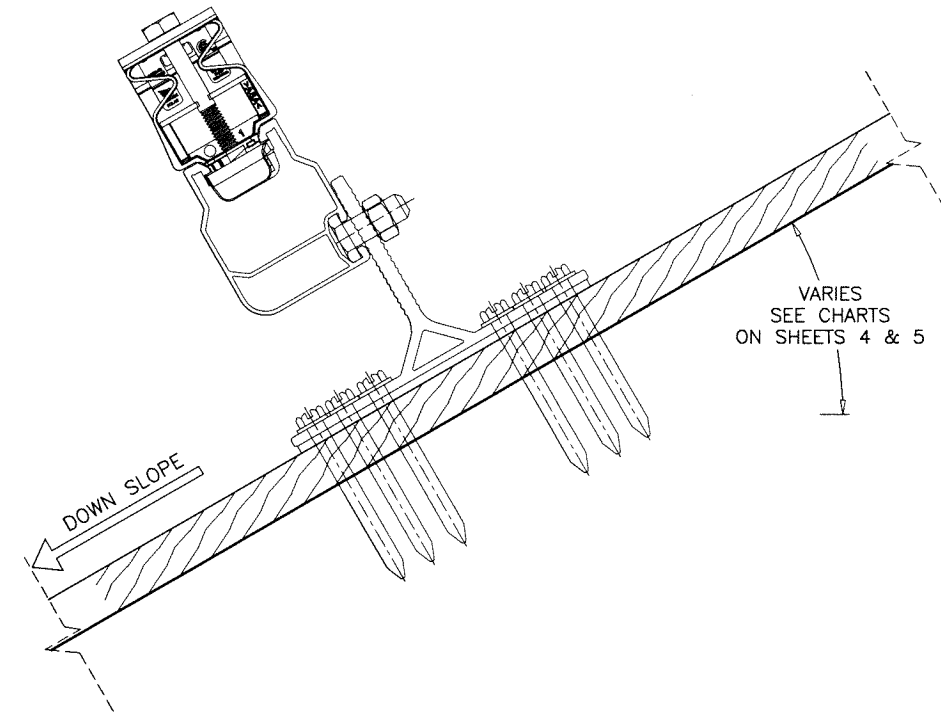
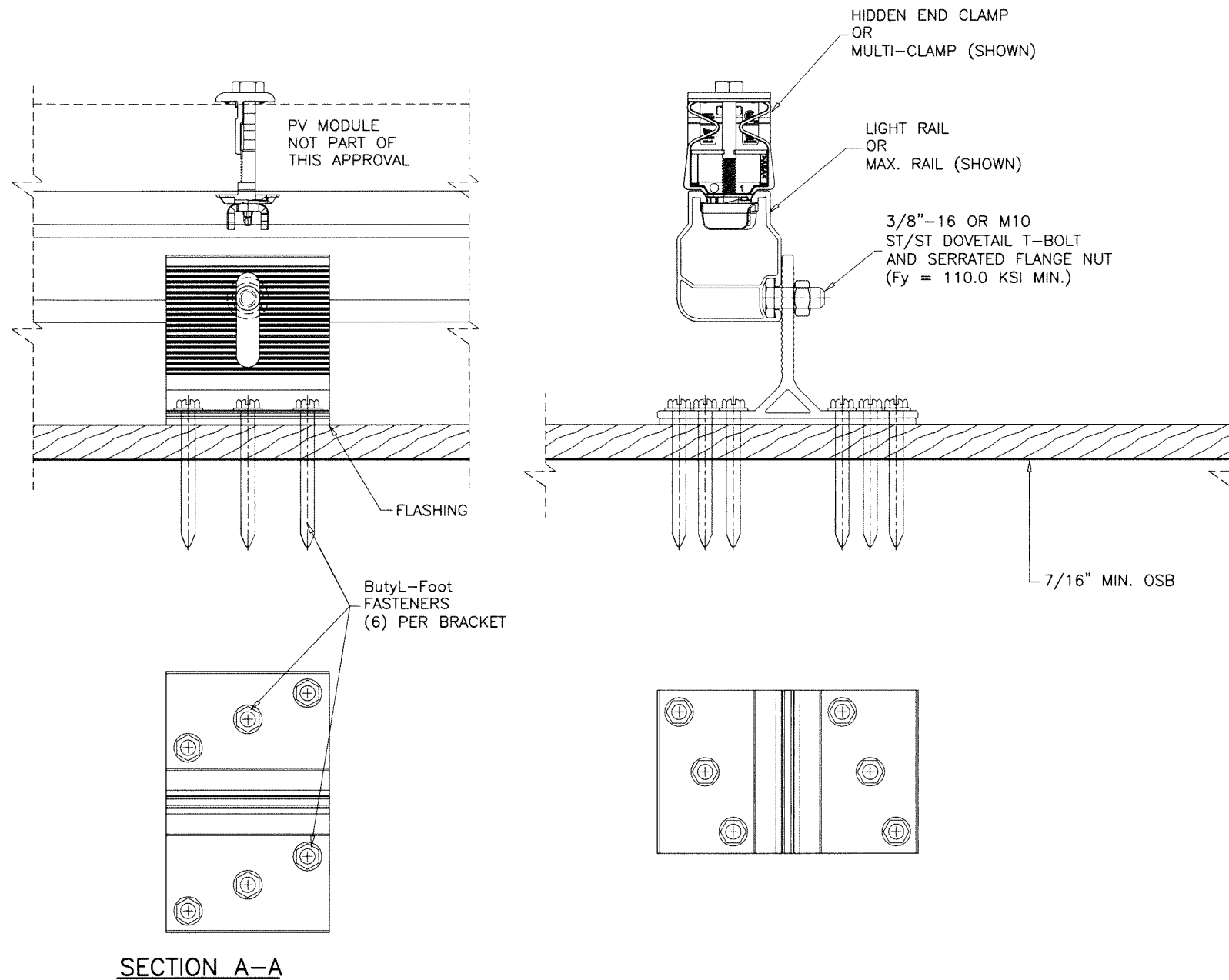

ButyL-Foot MOUNT FASTENERS:
#14 X 60MM WOOD SCREWS (F_y = 65 KSI MIN.)

WIND LOAD UPLIFT RESISTANCE (PERPENDICULAR TO ROOF) = 175.2 Lbs MAX.
 SHEAR RESISTANCE = 390.6 Lbs MAX.

Sealed: 8/11/2023

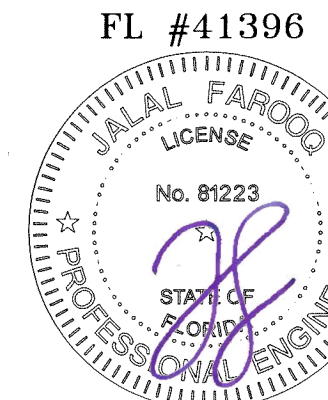

af c
AL-FAROOQ CORPORATION
 ENGINEERS & PRODUCT DEVELOPMENT
 9360 SUNSET DRIVE, SUITE 220
 MIAMI, FLORIDA 33173
 TEL. (305) 264-8100
 WWW.AFCENG.COM
 FBPE #3598
 SOLAR-RACK\23-37F-PS

ROOF TOP PV MOUNTING SYSTEM
Pegasus Solar Inc.
 506 West Ohio Avenue
 Richmond CA. 94804
 Phone: (510) 210-3797
 www.pegasussolar.com

revisions:	
no	date by description

date: 08-08-23
 scale: 3/8" = 1"
 dr. by: TARIQ
 chk. by:

drawing no.
23-37F
 sheet 6 of 6